

MP9000 Bender

More metal fabrication for your money



OPERATIONS MANUAL

METALpro

4715 136th Avenue, Hamilton, MI 49419
(262) 679-0504

metalprocorp.com



August 2022

TABLE OF CONTENTS

Introduction.....	1
Warranty	1
Return and Refund Policy.....	1
Safety	2
Unboxing and Installation Process	2
Operating Instructions	2
Machine Description	3
Dimensions and Capacity.....	4
Capacity.....	4
Specifications	4
Hardware and Components.....	4
Bill of Material	5
Leg Stand Assembly.....	6
Power Head Assembly	6
Exploded View.....	7
Hydraulic Installation	8
Ram Stroke.....	9
Maintenance	10
Optional Accessories	10

INTRODUCTION

This manual provides the information required for assembling, setting up, operating, and maintaining the **MP9000 Bender**. Included as a part of this manual are a replacement parts lists and assembly illustrations to guide you.

Included in manual are the specifications and capabilities of the Bender. If you have questions regarding the capabilities of the **MP9000 Bender** for a new application or need assistance in determining tooling requirements, please contact us at:

Metalpro Corporation

4715 136th Avenue
Hamilton, MI 49419
(262) 679-0504
info@metalprocorp.com

The first several pages of this manual view safety and cautionary information. This safety section summarizes the design safety elements, reviews WARNINGS, and lists the WARNING labels on the machine and accessories. It is your responsibility to understand all WARNINGS.

Observe all WARNINGS and CAUTIONS during installation, operation, servicing, and maintenance of the **MP9000 Bender**.

WARRANTY INFORMATION

Metalpro Corporation (seller) will, within one (1) year from date of purchase replace F.O.B. the factory, any goods which are defective in materials and/or workmanship provided the buyer, at the seller's option, return the defective goods prepaid to the seller. Punches, dies, and/or blades are warranted to be free of defects in materials and workmanship with thirty (30) days of purchase date.

This warranty does not apply to machines and/or components that have been altered, changed, modified in any way, subjected to abuse, abnormal use, inadequate maintenance, and lubrication, or subjected to use beyond recommended capacities and specifications. In no event shall the seller be liable for labor costs expended on such goods or consequential damages. Seller shall not be liable to purchaser or any other person for loss or damage directly or indirectly arising from the use of the goods, from any representations or warranty of fitness, or to waive any of the foregoing terms of sale, and none shall be binding on the seller.

This warranty is non-transferable.

RETURN AND REFUND POLICY

METALpro offers a 1-year limited manufacturing warranty on all METALpro machines from manufacturing defects.

- The Buyer has 30 days from date of delivery to contact the Seller regarding a return
- All METALpro returns are subject to a 20% restock fee
- The Buyer is responsible for shipping item back to METALpro at 4715 136th Ave Hamilton, MI 49419 and providing pictures showing condition of product before it ships
- The product needs to be in new/unused condition and be in original METALpro packaging for resale
- If not, Buyer is liable for cost to repair and repackage item additional to the 20% restock fee
- All returns are subject to METALpro's inspection at time of delivery

Any questions or concerns please contact METALpro's Customer Service at (262)-679-0504.

SAFETY

To prevent serious bodily injury:

- **Do not** operate, install tool, service, or adjust machine without proper instructions, reading, and understanding the operations manual
- **Do not** service the machine with electrical power connected
- **Do not** operate machine without push pin fully seated in die.
- **Do not** operate machine without both knurled pins fully inserted (pins must be in matching holes).
- **Do not** place any part of your body in the power head weldment during the bending operation.
- DO stand clear of the pipe, tubing, or other material during the bending operation.

SAFETY SUMMARY

- Wear approved eye protection when using the MP9000 Bender.
- Observe and follow the WARNINGS displayed on the MP9000 Bender and keep hands and clothing clear of all moving parts.
- The bending operation will cause the ends of the pipe to move inward and toward the rear of the machine. Make sure there is clearance for this movement. Keep your hands and clothing clear of the pipe as it is bent.
- Before doing any repairs on the MP9000 Bender, make sure it is unplugged.
- Any OSHA guarding requirements are the responsibility of the purchaser.

UNBOXING, INSPECTION, ASSEMBLY, AND INSTALLATION

For assembly and installation, refer to the exploded views as well as the bill of materials.

- Use a forklift or pallet jack to move the palletized **MP9000 Bender** as close as practical to the workstation where the bender will be assembled and installed.
- Unbox the bender.
- Ensure that instructional material and the packing list are preserved and that components are all accounted for prior to discarding the shipping materials.
- Carefully inspect bender and make sure that all items listed on the packing list are present.
- If damage is discovered, report the nature of the damage to the carrier. Replace any damaged components before using the bender.
- The installation site should be level.
- Tools required:
 - adjustable wrench
 - $\frac{3}{4}$ " wrench
 - $\frac{7}{16}$ " socket
 - $\frac{1}{2}$ " socket
 - $\frac{3}{4}$ " socket
 - $\frac{7}{16}$ " wrench

OPERATING INSTRUCTIONS

WARNING: WEAR APPROVED EYE PROTECTION WHEN OPERATING THE MP9000 Bender. OBSERVE THE WARNINGS DISPLAYED ON THE Bender, KEEP HANDS AND CLOTHING CLEAR OF ALL MOVING PARTS.

The movement of the foot switch determines the direction of travel. Depressing one foot switch causes the bender to extend the die forward and depressing the other foot switch causes the die to retract.

Releasing the foot switch, this stops, but does not reverse the travel direction.

Speed of travel is regulated by how long you depress the foot switch.

MP9000 Bender

More metal fabrication for your money

DESCRIPTION

The **MP9000 Bender** is a multipurpose bending machine. The straightforward design allows for quick set up and ease of use.

The **MP9000 Bender** is a single stroke machine. The foot switch controls stroke direction. When the pedal is held in one direction, the bender cylinder rod will travel in that direction and will stop only if the lever is released, or the maximum stroke is reached.



MP9000 Bender

More metal fabrication for your money

DIMENSIONS AND WEIGHT

Width 26 Inches
Height 43 Inches
Length 27 Inches
Weight Approximately 250 lbs. and includes packaging

OPERATIONAL CAPACITY

Approximately 4 to 5 strokes per minute for the smallest pipe
Maximum force 12 tons

BENDER CAPACITY

The **MP9000 Bender** easily handles a wide variety of professional, farm, and industrial production jobs. Using different dies, the machine can bend from $\frac{1}{4}$ " up to 2" schedule 40 pipe and schedule 80 pipe up to 90 degrees.

The same dies can also be used to bend solid rod and rigid electrical conduit up to 90 degrees in most cases. Dies for $\frac{3}{4}$ " to 2" heavy wall tubing is available. Call METALpro customer service to discuss specific requirements.

SPECIFICATIONS

Electrical Requirement 110V, 20 amp service
Hydraulic Power Self-contained, 2500 psi

HARDWARE AND COMPONENTS

Item	Description	Qty	Item	Description	Qty
6	$\frac{1}{2}$ -13 x 2 $\frac{1}{2}$ " hex head screw	4	1	power head weldment (includes items 4 & 5)	1
7	$\frac{1}{2}$ -13 lock nut	8	2	hydraulic cylinder (includes item 3)	1
8	$\frac{1}{2}$ " flat washer	8	31	upper shelf assembly	1
20	$\frac{5}{16}$ -18 x $\frac{3}{4}$ " carriage bolt	12		(includes items 9, 10, 13, 14, 15, 16, 17,	
21	$\frac{5}{16}$ -18 lock nut	12		18, 19, 20, 21, 25, 29, 30, 39, 40, 41,	
23	$\frac{1}{4}$ -20 x 2" hex head screw	2		42, 46, & 49)	
24	$\frac{1}{4}$ " flat washer	2	32	lower shelf	1
25	$\frac{1}{4}$ " lock nut	2	36	front panel	1
44	$\frac{1}{2}$ " - $\frac{3}{8}$ " steel reducer nipple	2	37	front leg (includes item 35)	1
45	$\frac{3}{8}$ " steel elbow	2	38	rear Leg (includes item 35)	1
47	$\frac{1}{2}$ -13 x 1 $\frac{1}{4}$ " carriage bolt	4			
48	$\frac{5}{16}$ " flat washer	12			

Above items are packed in a bag

MP9000 Bender

More metal fabrication for your money

BILL OF MATERIAL

Item	MP Number	Description	Qty
1	9013	power head weldment	1
2	9025	hydraulic cylinder (3½" bore x 8" stroke)	1
3	9017	push pin	1
4	9019	roller hourglass pin	2
5	9018	knurled pin	2
6	5066	½ -13 x 2½" hex head screw	4
7	5065	½ -13 lock nut	8
8	5012	½" flat washer	8
9	5022	⅜ -16 x 1" hex head screw	4
10	5023	⅜ -18 lock washer	4
20	5031	⅝ -18 x ¾" carriage bolt	12
21	5032	⅝ -18 lock nut	12
23	5036	¼ -20 x 2" hex head screw	2
24	5037	¼" washer	2
25	5038	¼ -20 Lock nut	10
31	5058	upper shelf	1
32	5057	lower shelf	1
35	5039	2" x 1½" plastic end cap	4
36	9022	front panel	1
38	5059	leg	2
40	5049	⅜" MPT street elbow	1
41	7031	⅝ -18 x 3" Hex head screw	4
42	5033	⅝" Lock washer	4
44	9026	½" to ⅜" Steel reducer nipple	2
45	9027	⅜" Steel elbow	2
46	5052	⅜" NPT x 3" Nipple	1
47	9032	1½" -13 x 1¼" Carriage bolt	4
48	5017	⅝" Flat washer	10
49	7029	¼ -20 x ¾" Hex head screw	8
50	6062/6060	Pump/Motor Assembly 110V 50HZ	1
51	6027/6049	Solenoid Valve 110V	1
52	6026 Dual	Foot switch	1
53	6048	⅜" X 30" Hydraulic Hose Assembly	2

LEG STAND ASSEMBLY – Refer to Figure 1

Step 1: Place the two legs (59) on edge and position the lower shelf (57) and the upper shelf (58) with pump/motor assembly between them.

Step 2: Install $\frac{5}{16}$ " -18 x $\frac{3}{4}$ " carriage bolts (31), $\frac{5}{16}$ " flat washers (17), and $\frac{5}{16}$ " -18 lock nuts (32) hand tight.

Step 3: Set the base upright. Put the dual foot switch (108) on the lower shelf (57).

Step 4: Viewed from the operating side of the Ironworker, the motor will be at the right side of the base.

Step 5: Make sure the legs and the shelves are properly positioned and square. Tighten the lock nuts on the backside of the bender. Leave the lock nuts on the front side hand tight until the front panel (62) is installed.

POWER HEAD ASSEMBLY – Refer to Figure 1

Step 1: Lift and position the power head assembly (1) on top of the leg stand and attach with four $\frac{1}{2}$ " -13 x $1\frac{1}{4}$ " carriage bolts (47) and four $\frac{1}{2}$ " -13 Lock nuts (7). Note: Cylinder mounting is over the rear leg (38).

Step 1: With cylinder parts facing downward, attach cylinder (2) to inside of the power head cavity using four $1\frac{1}{2}$ " -13 x $2\frac{1}{2}$ " hex head screws (6), four $\frac{1}{2}$ " washers (8), and four $\frac{1}{2}$ " -13 lock nuts (7).

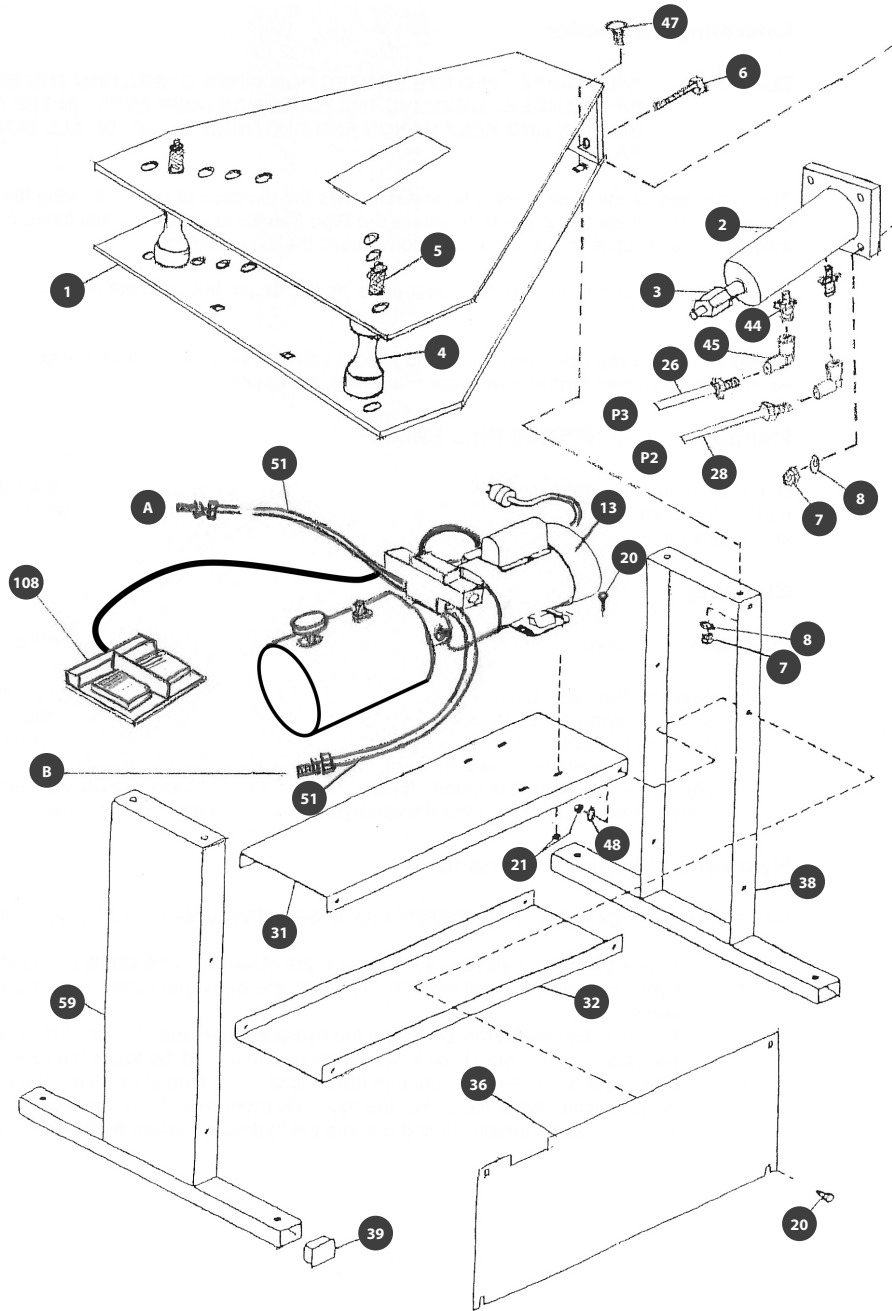

**FIGURE 1:
EXPLODED VIEW**

HYDRAULIC INSTALLATION – Refer to Figure 2

CAUTION: DO NOT ALLOW PIPE TAPE TO OBSTRUCT THE FITTING OPENINGS. IF YOU USE PIPE SEALANT, USE ONLY ENOUGH TO ACHIEVE A GOOD SEAL. DO NOT ALLOW ANY OF THE PIPE SEALING COMPOUND TO GET IN THE HYDRAULIC SYSTEM.

Assembly Instructions

Step 1: Connect the hydraulic hoses as shown.

WARNING: USE THE REAR PORTS OF THE CYLINDER ONLY. THE LOWER PORT ON THE LEFT SIDE OF THE CYLINDER MUST REMAIN PLUGGED.

Step 2: Tighten the fittings on the hydraulic hoses.

Step 3: Remove the breather/fill plug from the hydraulic reservoir.

Step 4: Fill the reservoir to within 1" of the top with Recommended ISO 32 Hydraulic Oil or AW/AL ISO 68 20W/20, ISO 32 10W, Mobil DTE 24-SSU, or equal hydraulic oil. Replace the breather/fill plug.

Step 5: Prime the hydraulic system as follows:

- Plug the Ironworker motor into a 110V, 20 amp circuit.
- Start the pump by switching on the motor.
- Using the foot switch, cycle the hydraulic cylinder up and down slowly. Complete ten cycles to make sure all the air has been purged from the hydraulic system.

CAUTION: AFTER THE HYDRAULIC SYSTEM HAS BEEN PRIMED, REMOVE THE BREATHER/FILL PLUG AND ADD HYDRAULIC OIL TO WITHIN 1" OF THE TOP OF THE RESERVOIR. OPERATING THE IRONWORKER WITH INADEQUATE HYDRAULIC OIL SUPPLY WILL CAUSE DAMAGE TO THE PUMP AND CYLINDER.

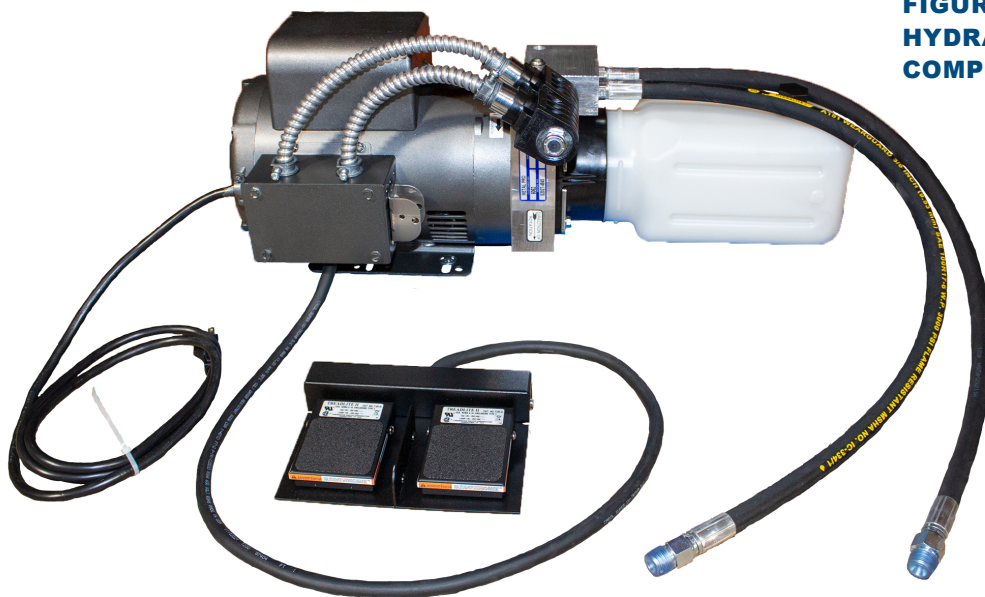
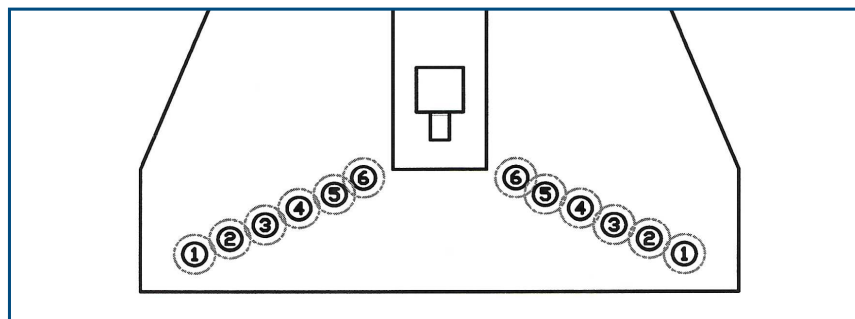

**FIGURE 2:
HYDRAULIC
COMPONENTS**

RAM STROKE

Tube Diameter – Nominal (inches)

Bend Angle Included Degrees	.500	.750	1.000	1.250	1.500	2.000
	Hole 5	Hole 4	Hole 3	Hole 2	Hole 2	Hole 1
90	3.106	4.453	5.711	6.320	5.622	6.907
95	2.974	4.245	5.441	6.007	5.365	6.634
100	2.843	4.040	5.176	5.699	5.106	6.356
105	2.710	3.837	4.916	5.396	4.845	6.073
110	2.576	3.636	4.658	5.094	4.582	5.784
115	2.440	3.435	4.402	4.793	4.315	5.489
120	2.303	3.234	4.146	4.492	4.044	5.187
125	2.163	3.032	3.890	4.190	3.768	4.878
130	2.021	2.828	3.632	3.886	3.486	4.560
135	1.875	2.622	3.373	3.578	3.199	4.234
140	1.726	2.413	3.110	3.266	2.904	3.899
145	1.573	2.201	2.843	2.948	2.602	3.553
150	1.416	1.984	2.571	2.625	2.291	3.196
155	1.255	1.762	2.294	2.294	1.971	2.828
160	1.088	1.535	2.011	1.955	1.640	2.446
165	.916	1.301	1.720	1.607	1.299	2.050
170	.738	1.061	1.420	1.248	.945	1.639
175	.552	.812	1.112	.878	.577	1.211



MAINTENANCE

During maintenance of the machine, check condition of all hydraulic and moving parts. Repair any damage and replace worn parts. Call METALpro customer service with any questions or concerns.

CLEANING

WARNING: ALWAYS WEAR EYE PROTECTION WHEN CLEANING THE Bender.

Step 1: Keep the bender clean by periodically remove chips, dirt, and debris from the bender, paying particular attention to the interior working cavity and around the cylinder and dies. Use an appropriate brush to remove heavy accumulations. During periods of heavy use, clean the bender more frequently.

Step 2: Wipe away any oil that is found. It may be hydraulic oil, which indicates there may be a leak in hydraulic system. Inspect the bender hydraulic system and repair any leaks for optimal performance.

HYDRAULIC SYSTEM MAINTENANCE

ISO 32 Hydraulic Oil or equivalent is recommended

(AW/AL Hydraulic Oil ISO 68 SAE 20W/20, ISO 32 SAE 10 WW, Mobil DTE 24-SSU, or equivalent oil)

Step 1: Check the entire hydraulic system for signs of leakage and check the condition of all hydraulic hoses at least monthly. Replace any damaged hoses and eliminate any leaks found.

Step 2: Remove the breather/fill plug from the hydraulic reservoir to check the oil level and condition. Add hydraulic oil if necessary to within 1" of the top of the reservoir.

Step 3: Check the oil condition. Although the oil is colored, it must be clean. If the oil is contaminated, drain the pump, the hydraulic cylinder, and the reservoir. Clean the interior of the reservoir. Fill and re-prime the hydraulic system as previously described.

OPTIONAL ACCESSORIES

Schedule 40/80 Pipe

Item	Bend Radius	Pipe
MP9015	8.31	2"
MP9016	6.65	1½"
MP9017	5.81	1¼"
MP9018	4.55	1"
MP9019	3.68	¾"
MP9020	2.94	¼ - ½"

Heavy Wall Tubing Dies

Item	Radius	Tubing O.D.
MP9034	1.50	½"
MP9036	2.94	⅝"
MP9038	2.94	¾"
MP9040	3.68	⅞"
MP9042	4.55	1"
MP9044	4.55	1⅛"
MP9046	5.22	1¼"
MP9048	5.81	1⅜"
MP9050	5.81	1½"
MP9052	6.65	1⅝"
MP9054	6.65	1¾"
MP9056	6.65	1⅞"
MP9058	8.31	2"